



Sample Gas Coalescing Filter K-AGF-PV-30-A

Gas analysis is a complex field. The sample gas to be analysed must be extracted and handled under quite diverse conditions to yield representative and reliable analysis results. One disturbance variable which must also be eliminated is aerosols.

The aqueous suspended particles can easily be removed from the gas by coagulation using special filter matrices. During this process, the tiny aerosols accumulate on the fibres of the filter matrix through collision, forming drops increasing in size. Once large enough, the condensate which forms drains into the filter bowl and is then removed.

Model K-AGF-PV-30-A uses the AGF-PV filter series housing made from PVDF and glass and has the respective fittings to adapt it to the coagulation function.

The easy installation and the Unique quick-release fastener are additional advantages of this model.

Bühler Unique quick-release fastener

Very quick and easy filter changes without tools

Variable wall mount

Additional connection inside the filter head (G1/4) for moisture detector or bypass

Allows the connection of automatic condensate drains



Dimensions

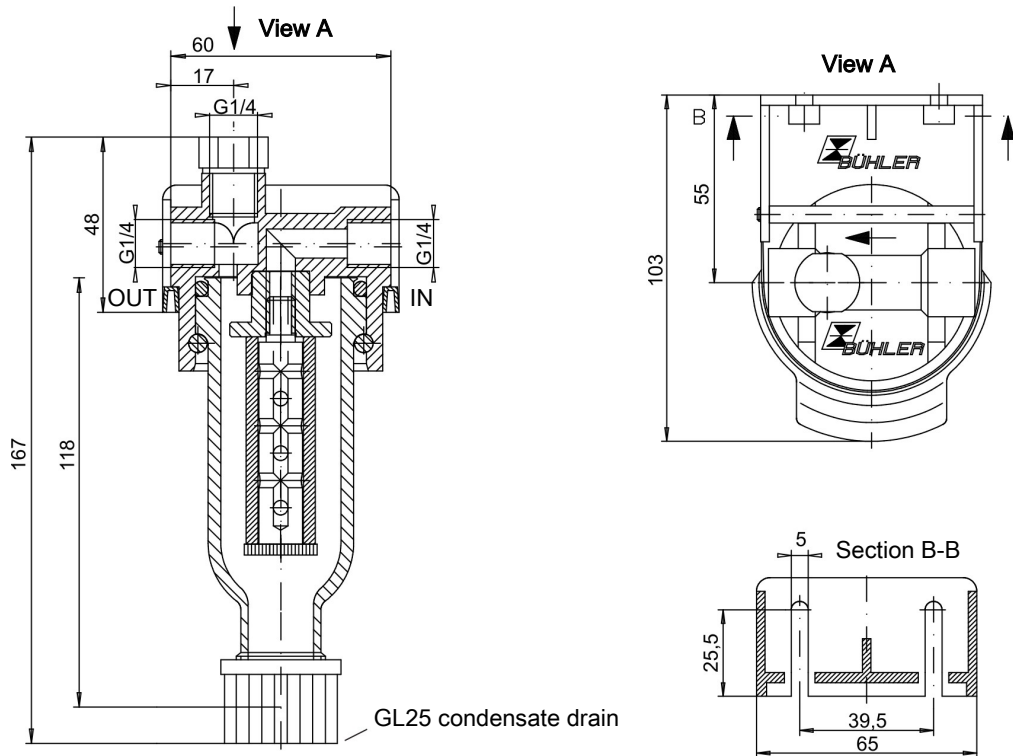

Use in explosive areas (additional notices):

The filter meets the fundamental safety requirements of Directive 2014/34/EU and is suitable for use in Category 2G, Explosion class IIB areas. The filter is not marked, as it does not have an innate ignition source and Directive 2014/34/EU therefore does not apply.

Flammable gases, explosion class IIB or IIC, which could occasionally be explosive during normal operation may be conveyed through the filter.

Be sure to observe the instructions in the respective operating instructions!

Ambient temperature range for Ex area applications: $-5\text{ °C} \leq T_{\text{amb}} \leq 60\text{ °C}$.

Technical Data

K-AGF-PV-30-A Coalescence Filter

Dead volume	73 ml
Material – Filter head	PVDF
Material – Filter cover	Glass
Material – Gasket	Viton
Thread	G1/4 or NPT 1/4" (see ordering information)
Weight	0.24 kg
Operating pressure max.	4 bar
Operating temperature max.	100 °C

Ordering instructions

Filter*

Item no.	Model	Seal
41 50 699	K-AGF-PV-30-A; G1/4 outlet and inlet	Viton
41 42 699I	K-AGF-PV-30-A-I; NPT 1/4" outlet and inlet	Viton

* one filter element is included with delivery.

Filter element

Item no.	Model	Filter element	Material	Filter surface	VE	Ex application
49 32 002	12-57-C	Screw-in sleeve	Borosilicate fibre	28 cm ²	1 count	IIC