



Portable sample gas conditioning PCS.base

In addition to stationary analysers, gas analysis for monitoring emissions also uses portable methods. The actual measuring task determines the complexity of the sampling/analysis units. Since not all control points are easy to access, operators are interested in suitable and light equipment with a small pack size. Even under this premise, extracting the sample gas must meet high standards to ensure the measurements are reliable.

Depending on the application, this also requires conditioning the sample gas on site.

The PCS Base portable gas conditioning system has a gas cooler to lower the dew point and separate condensation, particle filter, condensate trap and pump. The entire unit comes inside a compact, light carrying bag which also has room for electric lines and the simple Baseline sample gas probe.

Developed for mobile gas analysis

Optimal for probe type Baseline

Compact design

Ideal for service, comparison- and sample measurement

System and accessories built into a lightweight transport bag

Consists of cooler with condensate trap, filter and pump

Moisture detector, flow meter and various accessories optional

Selectable Delta-T control for optimal cooling capacity

Adjustable outlet dew point and alarms



Description

Accurate gas analyses in changing locations require compact gas conditioning systems. The PCS.base was developed for these applications.

The low weight and small dimensions of the system are ideal for e.g. service engineers using sample- or comparison measurements.

A carrying bag provides reliable protection from the weather and mechanical damage to the product and allows for convenient system transport.

The base version of the gas condition system consists of a gas cooler with condensate trap, a gas pump and filter. For more accessories and options please refer to the table in the data sheet.

The sample gas is cooled to the preset dew point (factory preset 5 °C) regardless of the ambient temperature. This safely falls below the dew point and moisture in the sample gas is separated as condensate. A safety circuit only starts the gas pump once the operating point of the cooler has been reached. The optional moisture detector communicates with the sample gas pump, switching it off in the event of water burst or cooler overload.

Additional options or variations are also available if necessary.

Consists of

- Hose nipple connection
- TC-MINI with control
- Condensate trap
- Filter
- Pump
- Flow meter
- Moisture detector optional

- Transport bag of fire-retardant, high-quality material to hold Baseline, Baseline accessories and spare filters
- Operation with open transport bag

Flow chart

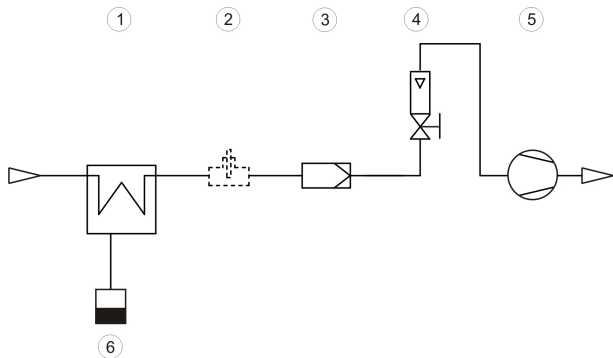

1 Cooler	4 Flow meter with needle valve (optional)
2 Moisture detector (optional)	5 Pump
3 Filter	6 Condensate trap

Delta-T Control

The PCS.base generally provides the operator with two options to adapt the system function to the ambient conditions or the main areas of measurement.

Sturdy dew point conditions inside the gas cooler are seen alongside against safe gas drying whilst utilising the maximum cooling capacity.

1. Adjustable output dew point

An output dew point of 3, 5, 10 or 15 °C can be set to reach the specified values. Here it's important the ambient temperature is always ABOVE the output dew point setting, or condensation may form in the lines after the cooler. So the ambient temperature range is limited.

2. Delta-T Control

Here the electronics regulate the output dew point to a value about 15 °C or 30 °C lower, but no less than the dew point set under 1). This extends the potential cooling capacity to the limits of the heat exchanger. Here it's important to note the output dew point fluctuates along with the ambient temperature and a stable dew point cannot be a prerequisite for the measurement.

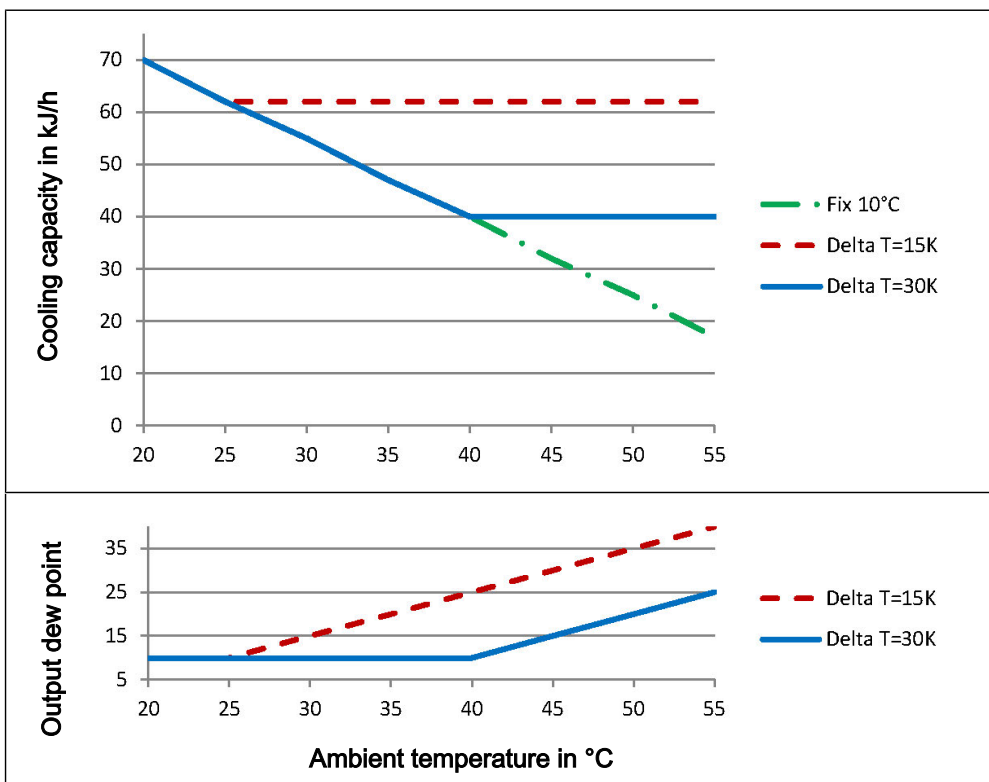

Technical Data

General

Technical Data PCS.base

Ready for operation	at TU = 25 °C after approx. 10 minutes
Ambient temperature	5 °C to 45 °C
Gas inlet temperature	80 °C
Gas output dew temperature, preset	5 °C
Dew point stability	± 0.2 K
Max. pressures	1 bar
Flow rate	110 L/h max.
Rated cooling capacity at 25 °C and dew point	5 °C: 55 kJ/h 10 °C: 60 kJ/h 15 °C: 65 kJ/h

Electrical specifications

Electric supply

Power supply	110 – 260 V AC, 50/60 Hz
Electrical connection	IEC connector

Mechanical specifications

Hose connections	Inlet: DN 6 hose nipple PVDF Outlet: DN 4 hose nipple PVDF
Weight excl. accessories	6.8 kg
Weight incl. probe and accessories	approx. 10.5 kg
Dimensions (w x h x d)	approx. 480 x 270 x 260 mm

Materials

Parts in contact with medium

Heat exchanger, filter, tubing, pump	PVDF, PC, PTFE, Viton, EPDM, PP, PVC
Optional moisture detector	PVDF, stainless steel 1.4571 / 1.4576, epoxy resin
Optional flow meter	PP, glass, Viton

Dimensions



Dimensions: approx. 480 x 270 x 260 mm (w x h x d)

Ordering instructions

The item number is a code for the configuration of your unit. Please use the following model key:

PCS:

CSP B10 0000	PCS.base
CSP B11 0000	PCS.base with moisture detector
CSP B10 1000	PCS.base with flow meter with needle valve
CSP B11 1000	PCS.base with flow meter with needle valve and moisture detector

Spare parts and accessories

Item no.	Description
	Spare filter
41 15 00 90	AGF-FE-1T, 2 µm, 80 °C (176 °F), Unit: 5 count
	Connection hoses
90 14 033	PVC hose DN 4/6 (for gas outlet)
90 14 136	Viton hose DN 4/6 (for gas outlet)
90 14 036	PVC hose DN 6/8 (for gas inlet)
90 14 138	Viton hose DN 6/8 (for gas inlet)

For more information on the Baseline probe and suitable accessories please refer to data sheet 464001.